



LITTER BIN 50 LITRE IN ACCORDANCE WITH DIN 30713

Nominal Volume: 50 l

Empty weight: 4.0 kg

Dimensions (W/D/H): 432 x 334 x 745 mm

- manufactured from HDPE using the compact injection moulding process in accordance with DIN 30713
- resistant to UV, cold, heat and chemicals
- easily mounted on posts, trellises and walls
- body can be emptied or exchanged by simple release with a triangular key
- galvanised metal parts
- available in standard orange (RAL 2010) or green (RAL 6011) other colours on request

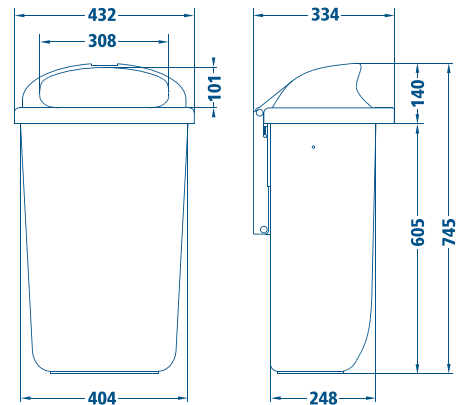

PRESORTING CONTAINERS 10 LITRE

Nominal Volume: 10 l

Empty weight: 500 g

Dimensions (W/D/H): 208 x 279 x 309 mm

- manufactured from HDPE using the compact injection moulding process
- resistant to UV, cold, heat and chemicals
- galvanized steel wire folding handle
- standard markings on the lid: neutral or Weber
- available in brown or green



We reserve the right to make dimensional and constructional alterations.